

# TECHNICAL RIDER

( 23/01/2024)

« HHH »

## COMPANY ENTITY

duration : 50 minutes

*This rider is contractual. Please initial and sign for agreement.  
Please feel free to contact us in case of difficulty.*

### CONTACTS

#### Artistic

**Thibaut EIFERMAN**

Mobile : +33 (0) 7 75 69 53 59

Email : [thibauteiferman@gmail.com](mailto:thibauteiferman@gmail.com)

#### Administration

**Anne GEGU**

Mobile : +33 (0) 6 11 17 63 85

Email : [gegu.anne@gmail.com](mailto:gegu.anne@gmail.com)

#### Production Manager

**Noëlle Géranton**

Mobile : +33 (0) 1 53 61 16 76

Email : [noelle@dddames.com](mailto:noelle@dddames.com)

#### Stage Management

**Laurent PATISSIER**

Mobile : +33 (0) 6 86 78 29 79

Email : [laurentpatisier@aol.com](mailto:laurentpatisier@aol.com)

#### Touring staff

5 people: 3 dancers, 1 stage manager, 1 production manager

## **I - AUDIENCE**

- All audiences
- Gauge: unlimited

## **II - STAGE**

- Opening: 11 m ideal, 9 m minimum
- 13 m wall to wall minimum
- Depth: 10 m ideal, 8 m minimum
- Height: 5 m minimum
- Curtains : 5 wings of black curtains

The scenography consists of a white dance floor 8m wide by 7m deep, framed by a black dance floor, to be supplied by the venue.

If the back wall is black or dark and in good condition, we play without a backdrop. If not, please provide a black backdrop.

Thank you for providing a good haze machine, such as MDG.

For a small confetti release from the grid, please provide 1x PAR64 empty carcasse, 2x single pulley, 1x 20m black rope, and a small ballasted machinery stand.

## **III - LIGHTING**

To be supplied by the host venue

- 1 lighting desk with memories and time delays, 68x 3Kw dimmers, 2x 5Kw dimmers
- 28 PC 1 Kw
- 12 PC or Fresnels 2 Kw
- 2 Fresnels 5Kw
- 26 16/35° zoom profile 1 Kw ( type Juliat 614 ) , 6 of which can be replaced by BT 250 or 500 w
- 6 28/54° zoom profile 1 Kw ( type Juliat 613 )
- 8 16/35° zoom profile 2 Kw ( type Juliat 714 )
- 3 28/54° zoom profile 2 Kw ( type Juliat 713 )
- 16 asymmetrical cycliodes 1 Kw
- 19 PAR 64 CP62
- 8 PAR 64 CP61
- 6 iris for 16/35° 1Kw zoom profile
- 10 floor plates
- 8 small stands ht = 1.20m
- 6 large feet ht = 3.50m (spotlights installed on these feet can also be installed on front to back pipe, side grids, etc.)
- Backstage light (left and right backstages)

- Filters, ref. Lee Filters, to be supplied by the venue:

FORMA GELAT	PC 1KW	PC 2 KW	Déc 1KW	Déc 2KW	PAR 64	Cyclio de	5 Kw
002	18						
128					18	8	2
500				3			
501	10	12	10	8		8	
503			16		8		

Ref. Rosco Supergel : #114 8x PC 1Kw, #119 12x PC 2Kw, 20x PC 1Kw

## IV – SOUND

- source: we bring a Mac laptop, please provide the necessary cabling to connect it to the sound console.
- 1 front adapted to room size
- 4 stage monitors

## V - SET-UP AND PERSONNEL

- 12 hours working the day before the show if pre-assembly is not possible
- 8 hours working the day before the show if pre-assembly is **complete**

One stage manager and one sound manager are required for each rehearsal and performance

	Day before show	D-Day
Morning call	<b>Lighting set-up and adjustments</b> -1 lighting director -1 electrician (or more if no pre-assembly) -1 stage manager (+ 1 machinist if no pre-hanging)	<b>Technical finishes and rehearsal</b> - 1 lighting manager - 1 electrician - 1 stage manager
Afternoon call	<b>Light focus and sound</b> Same team plus a sound manager	<b>Rehearsal</b> - 1 stage manager - 1 sound manager
Evening call	<b>Technical finishes if needed and rehearsal</b> Same team	<b>Show</b> Same team

- Disassembly and loading : 1 h , 2 people

## VI - DRESSING ROOMS

- Dressing rooms for 3 people
- Please bring cookies, fruit, mineral water, local specialties...

This technical specification is ideal. You can be sure that, as soon as we receive your technical rider and stage plots (to scale), we will adapt these technical requirements to the possibilities of your venue.



Scale 1/50

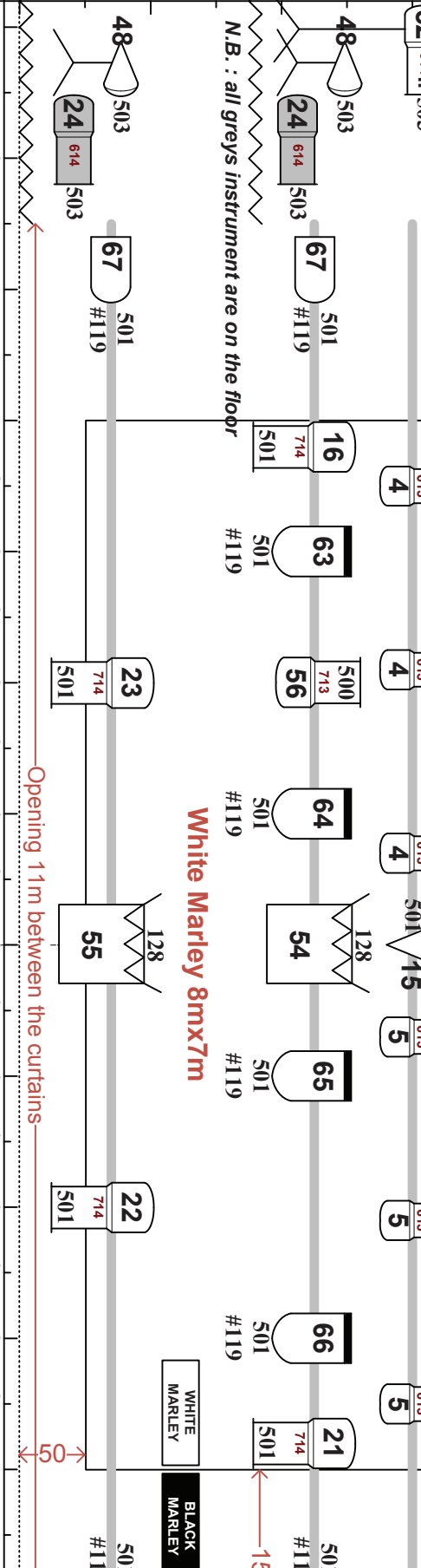
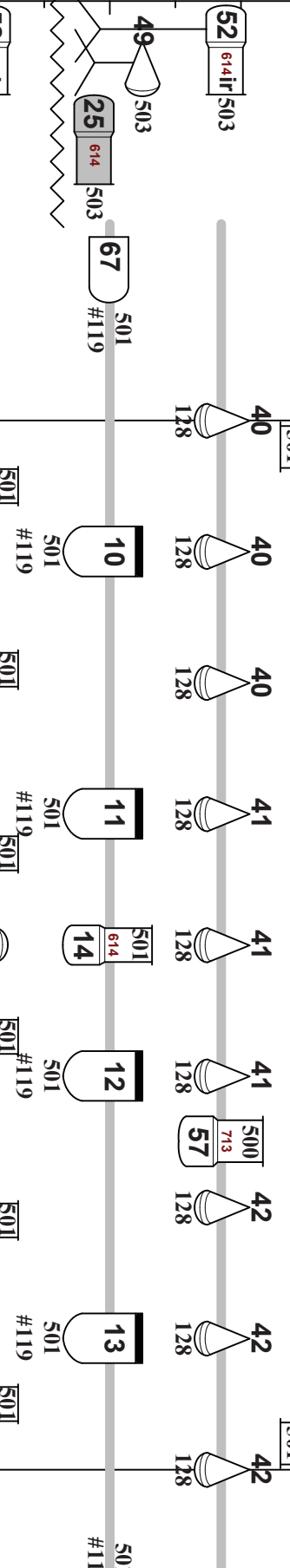
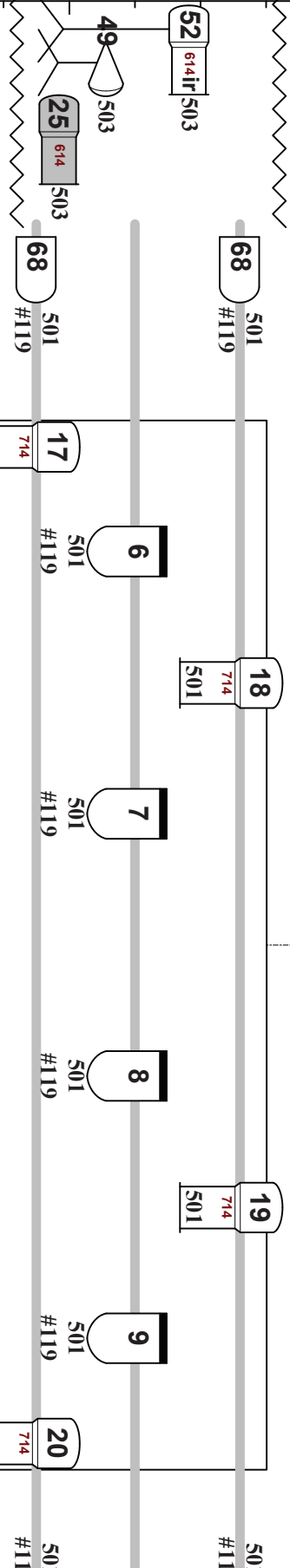
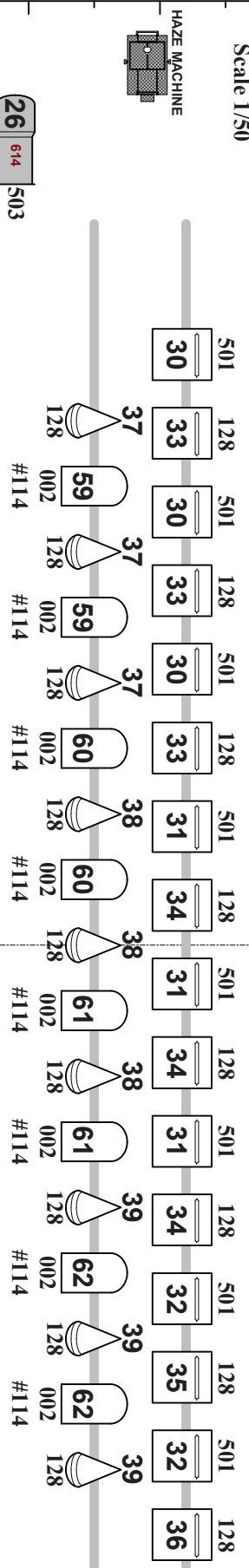
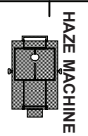

N.B. : all greys instrument are on the floor

White Marley 8mx7m

WHITE MARLEY  
BLACK MARLEY

Opening 11m between the curtains

$h=+1, 20m$

$h=4m$

150

50

# INSTRUMENT KEYS

0 PC 1 Kw

0 PC 2 Kw

0 FRESNEL 5Kw

0 714 SHORT PROFILE 2 Kw TYPE JULIAT 714

0 713 ULTRA SHORT PROFILE 2 Kw TYPE JULIAT 713

0 614 SHORT PROFILE 1 Kw TYPE JULIAT 614

0 613 ULTRA SHORT PROFILE 1 Kw TYPE JULIAT 613

0 PAR 64 CP62

0 PAR 64 CP61

0 ASYMETRICAL CYCLIODES 1Kw

BLACK CURTAINS

## FOH

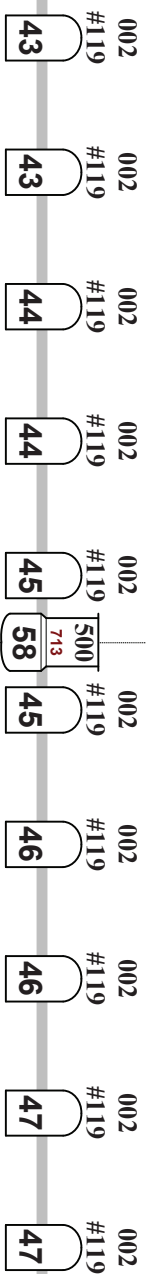

Between 3 or 4 m from the front stage

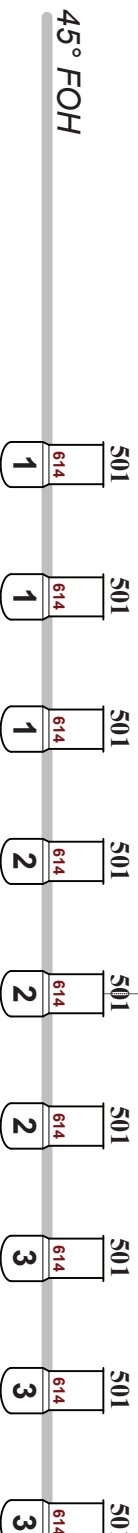

45° FOH

7 6.5 6 5.5 5 4.5 4 3.5 3 2.5 2 1.5 1 0.5 0 0.5 1 1.5 2 2.5 3 3.5 4 4.5 5 5.5 6 6.5 7